

PVDF PUMP SERIES

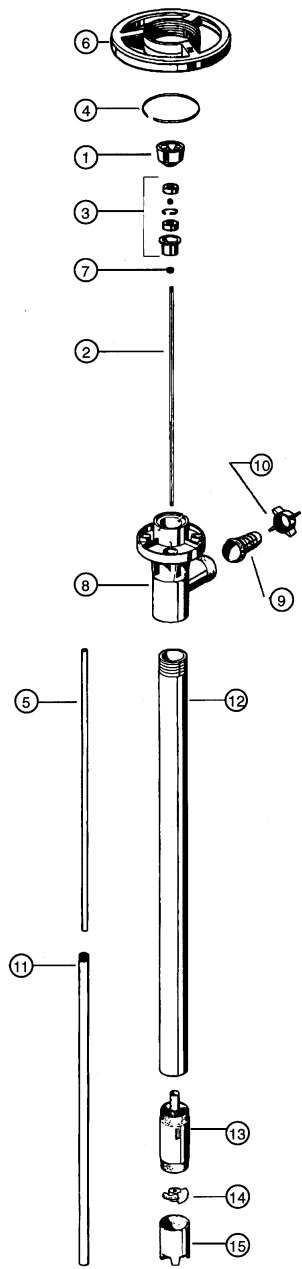

ITEM NUMBER	DESCRIPTION	PART NUMBER
1	Pump coupling	1004
2	Drive shaft 27" (700 mm)	1543
	39" (1000 mm)	1544
	47" (1200 mm)	1545
	50" (1270mm)	1549
	60" (1400 mm)	1546
	72" (1800 mm)	1547
3	Bearing unit assembled - 2 each Viton shielded bearings, spacer, snap ring, bearing can	1038
4	Snap ring	1508
5	Guide sleeve - TFE 27" (700 mm)	1516
	39" (1000 mm), 47" (1200 mm), 50" (1260 mm)	1514
	60" (1500 mm), 72" (1800 mm)	1661
6	Hand wheel	1842
7	V-seal - TFE	4000
8	Discharge housing	4028
9	Hose barb, 3/4" (22 mm)	4051
	1" (25 mm)	4082
10	Wing nut	4106
11	Inner tube, 27" (700 mm)	4600
	39" (1000 mm)	4601
	47" (1200 mm)	4602
	50" (1270 mm)	4623
	60" (1500 mm)	4615
	72" (1800 mm)	4618
12	Outer tube, 27" (700 mm)	4604
	39" (1000 mm)	4603
	47" (1200 mm)	4605
	50" (1270 mm)	4622
	60" (1500 mm)	4617
	72" (1800 mm)	4619
13	Pump housing includes carbon bushing	4607
14	Impeller - PVDF High pressure rotor	4608 4608HH
15	Pump foot High pressure pump foot	4609 4609HH