

SP-800SR SANITARY SERIES SPARE PARTS

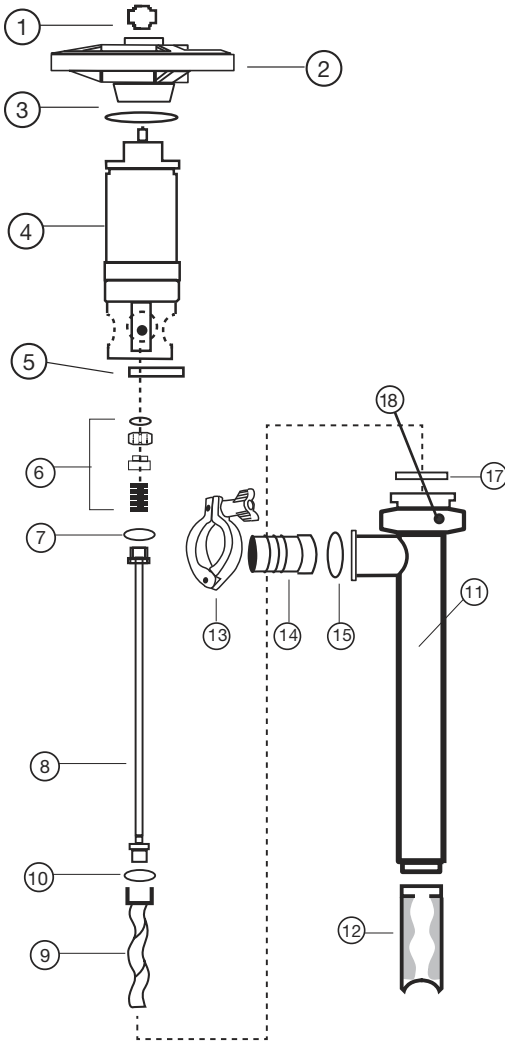

ITEM NO.	DESCRIPTION	PART NUMBER
1	Pump Coupling	1004
2	Hand Wheel	1842
3	Snap Ring	1508
4	Gear Reduction Unit	701
5	Mechanical Seal Bushing	702
6	Mechanical Seal, SIC	703
7	Gasket	
	BUNA	734
	PTFE	735
8	Drive Shaft, SS316	
	Pump Sizes - SP-751-27,SP-752-27,SP-1851-27	704
	Pump Size - SP-1851-39	705
	Pump Sizes -SP-751-39,SP-752-39,SP-1851-47	706
	Pump Sizes - SP-751-47,SP-752-47	707
9	Rotor	
	Size 751	708
	Size 752	709
	Size 1851	710
10	Gasket	
	BUNA	733
	PTFE	731
11	Outer Tube Assembly	
	Pump Sizes - SP-751-27,SP-752-27,SP-1851-27	800
	Pump Size - SP-1851-39	801
	Pump Sizes -SP-751-39,SP-752-39,SP-1851-47	802
	Pump Sizes - SP-751-47,SP-752-47	803
12	BUNA, FOOD GRADE	
	Size 751	716
	Size 752	717
	Size 1851	718
	PTFE	
	Size 751	722
	Size 752	723
	Size 1851	724
13	Tri-Clamp	833
14	Hose Barb	
	1.25 (32 mm)	834
	1.5 (38 mm)	835
15	O-Ring - PTFE	837
	O-Ring - BUNA	836
16	Optional Motors	page 7
17	Gasket	
	BUNA	737
	PTFE	738
18	Set Screw	757