

POLYPROPYLENE PUMP TUBE SERIES

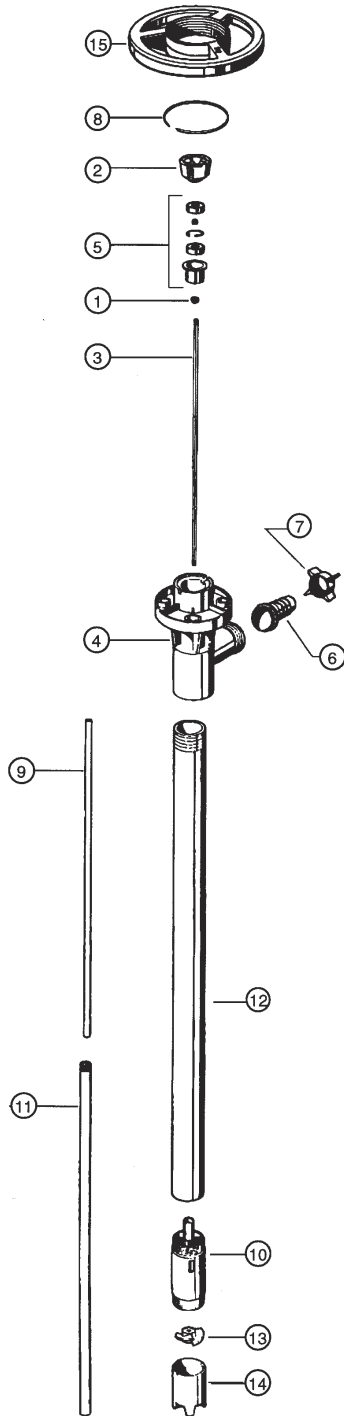

ITEM NO.	DESCRIPTION	PART NUMBER
1	V-seal - Viton	1000
2*	Pump coupling	1004
3	Drive shaft, 27" (700 mm)	1543
	39" (1000 mm)	1544
	47" (1200 mm)	1545
	60" (1400 mm)	1546
	72" (1800 mm)	1547
4	Discharge housing	1028
5*	Bearing unit assembled - 2 each Viton shielded bearings, spacer, snap ring, bearing can	1038
6	Hose barb, 3/4" (22 mm)	1051
	1" (25 mm)	1082
7	Wing nut	1106
8*	Snap ring	1508
9	Guide sleeve - TFE 27" (700 mm), 39" (1000 mm), 47" (1200 mm)	1514
	60" (1500 mm), 72" (1800 mm)	1661
10	Pump housing includes carbon bushing	1524
11	Inner tube, 27" (700 mm)	1600
	39" (1000 mm)	1601
	47" (1200 mm)	1602
	60" (1400 mm)	1615
	72" (1800 mm)	1616
12	Outer tube, 27" (700 mm)	1604
	39" (1000 mm)	1603
	47" (1200 mm)	1605
	60" (1400 mm)	1617
	72" (1800 mm)	1618
13	Impeller High pressure impeller	1608 4608 HH
14	Pump foot High pressure pump foot	1609 1609 HH
15*	Hand wheel	1842

*Parts interchange with all pump tubes.

! Polypropylene pumps should not be used to pump flammables.